

## Venturi Device 7005-BF-2013/E

**1-circuit vacuum lifting  
device according to  
EN 13155**



vertical

### Description

- **1 circuit vacuum system**
- the vacuum circuit has a vacuum tank with non-return valve, vacuum switch and control vacuum meter
- **completely closed vacuum circuit**  
prevents loss of vacuum at compressed air failure
- **power failure monitoring system**
- acoustic signal  
reports insufficient vacuum/drop in air pressure
- 2 flexibly separated movable suction cups
- carrying belts prevent damage to the transport load

### Vacuum generation

- via built-in suction jet (Venturi)  
for operation at least 6 bars compressed air are necessary
- optional air pressure switching

### Operation

- ON/OFF directly at the device
- SUCTION / RELEASE via a manual slide valve with locking in the SUCTION position

**Suspension:** crane eye at the carrying frame /  
2-fold crane string

**Load capacity :** **200kg/250kg**  
**Colour:** yellow / partly zinked

<b>suitable for lifting</b>		
material properties	gas-tight	
surface	smooth	
e. g.	glass panes, sealed units, window and curtain walling elements, plastic and ceramic plates, coated boards	
<b>suction cup type</b>	<b>388</b>	<b>488-K</b>
<b>diameter</b> in action approx. mm	300	350
<b>quality of suction cups</b>	black rubber abrasion possible up to 80° C heat resistant from 4 mm glass thickness	rubber red abrasion possible up to 80° C heat resistant from 3 mm glass thickness
<b>number of suction cups</b>	2	
<b>safe working load</b> on smooth and clean surface at 60 % vacuum		
<b>in-company</b> kg	200	250
<b>outer distance of the suction cups</b> approx. mm	650 - 1340	700 - 1390
<b>dead weight</b> approx. kg	26	28
<b>air pressure connection</b>	9 mm	
<b>Item No.: 7005-BF-2013/E...</b>	<b>200</b>	<b>250</b>
<b>Accessories on request</b>		
<b>Item No.: OPT-DLSpar</b>	air pressure saving switching – saves approx. 50% of the air pressure consumption	
<b>Item No.: OPT-388TR</b>	device equipped with : mark-free suction cups for coated glass	
<b>Item No.: OPT-388K</b>	device equipped with : softer suction cup for thinner glass	

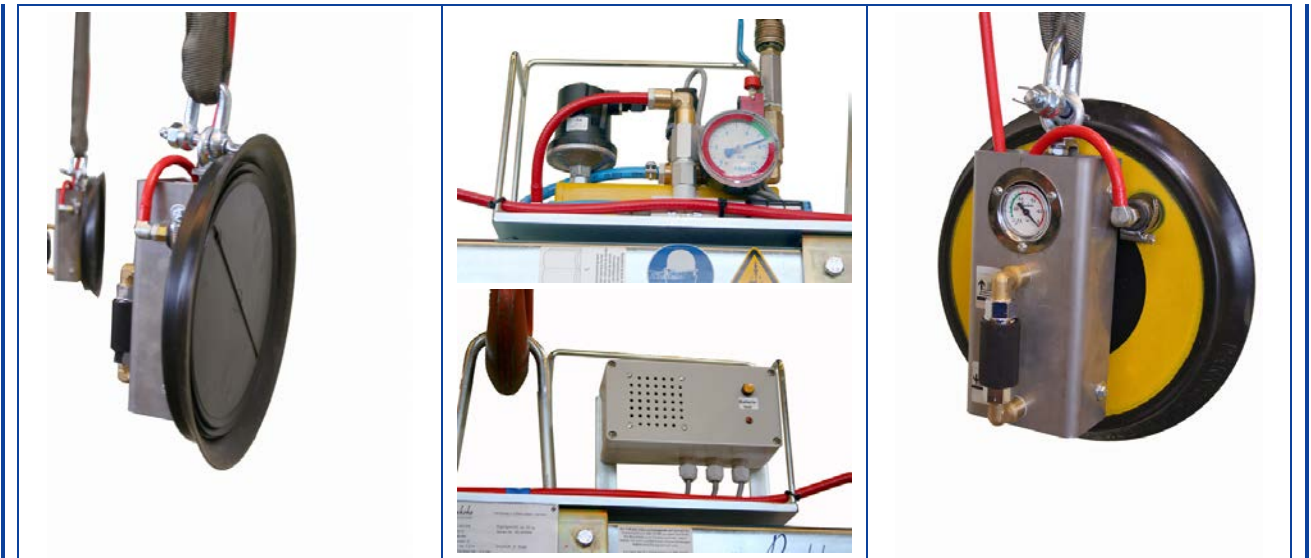

Venturi Device 7005-BF-2013/E with 2 suction cups 388

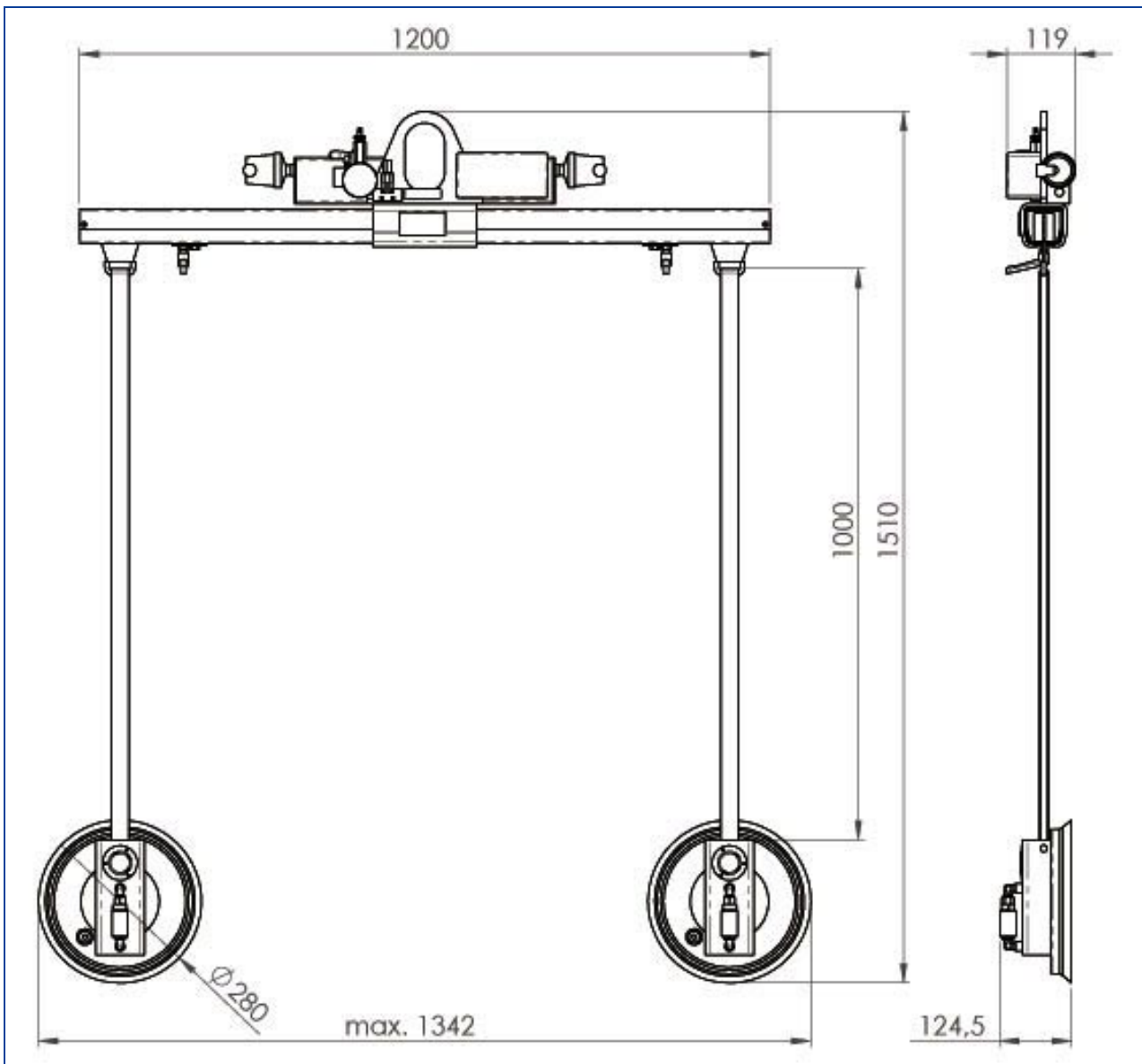



**Do you want to learn more?**

**Use the QR code for the video and you will also learn more about the device.**

**Or click on the picture.**

